

DIAPHRAGM SENSING PRESSURE REDUCING VALVE P7

DESCRIPTION

The ADCA P7 series direct acting, spring-loaded diaphragm sensing pressure reducing valves, are designed for use with steam, compressed air and other gases compatible with the materials of construction.

They are suitable for pressure reducing stations where very small loads are involved. They are also specifically recommended to operate as pilot valves in combination with other pressure regulators.

MAIN FEATURES

Compact design.
 Stainless steel diaphragm.

OPTIONS: 1/4" gauge connection on body.
 Regulating screw with top cap.
 External sensing connection.
 Low pressure top.
 Dome loaded version.
 Bar stock stainless steel construction.

USE: Steam, compressed air and other gases compatible with the construction.

AVAILABLE MODELS: P7SS – stainless steel construction.

SIZES: 1/4" and 3/8".

CONNECTIONS: Female threaded ISO 7 Rp or NPT.

INSTALLATION: Horizontal installation.
 A strainer should be installed upstream of the valve.
 See IMI – Installation and maintenance instructions.

ORDER REQUIREMENTS: Type of fluid.
 Maximum operating temperature.
 Inlet and outlet pressures.
 Flow rate (maximum and minimum).



CE MARKING – GROUP 2 (PED – European Directive)	
PN16 / PN40	Category
1/4" and 3/8"	SEP

CAPACITIES		
Valve size	1/4"	3/8"
Kvs (m ³ /h)	1	1,1

LIMITING CONDITIONS	
Valve model	P7
Body design conditions	PN40
Maximum upstream pressure (steam)	25 bar
Maximum upstream pressure (gases)	31 bar
Maximum downstream pressure	17 bar
Minimum downstream pressure *	0,35 bar
Maximum design temperature	300 °C

* 0,07 bar with low pressure top (limited at 7 bar inlet).
 The low pressure diaphragm should be fitted for outlet pressures from 0,07 up to 0,5 bar.
 Pressure and temperature limiting conditions may change if soft seating is used.

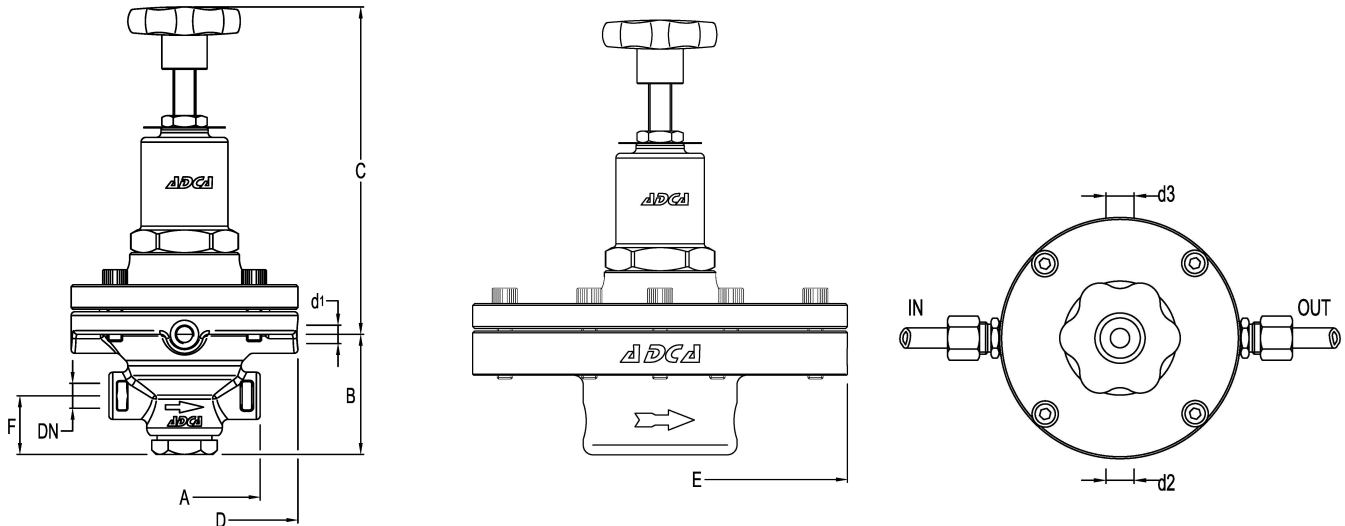

DIMENSIONS (mm) - THREADED

SIZE	A	B	C	D	E *	F	d1 **	d2 ***	d3 ***	WEIGHT (kg)
1/4"	80	63,5	185	120	195	31	1/8"	1/4"	1/4"	4,8
3/8"	80	63,5	185	120	195	31	1/8"	1/4"	1/4"	4,8

* Low pressure top (bar stock construction); ** Optional external sensing connection; *** Optional pressure gauge connections.
Remarks: All optional threaded connections are supplied in accordance with the main connections.

MATERIALS

POS. N°	DESIGNATION	MATERIAL
1	Valve body	AISI 316 / 1.4401 ; CF8M / 1.4408
2	Plug	AISI 316 / 1.4401
3	*Gasket	Stainless steel / Graphite
4	*Strainer screen	AISI 304 / 1.4301
5	Gasket	Copper
6	*Spring	AISI 302 / 1.4300
7	*Valve head	AISI 420-EPDM-PTFE, etc.
8	*Pilot valve body	AISI 316 / 1.4401
9	*Pushrod	AISI 316 / 1.4401
10	*Diaphragm	AISI 301 / 1.4310
11	*Gasket	Stainless steel / Graphite
12	Top cover	CF8 / 1.4308
13	Cover spring	CF8 / 1.4308
14	Lower spring carrier	Brass
15	Top spring carrier	Brass
16	*Adjustment spring	Spring steel
17	Spring id. plate	Aluminium
18	Locknut	Stainless steel A2-70
19	Handwheel	Plastic
20	Bolts	Stainless steel A2-70
21	Restrictor	Stainless steel A2-70

* Available spare parts.

Remarks: All valves have a serial number. In case of non-standard valves this number must be supplied if spare parts are ordered.

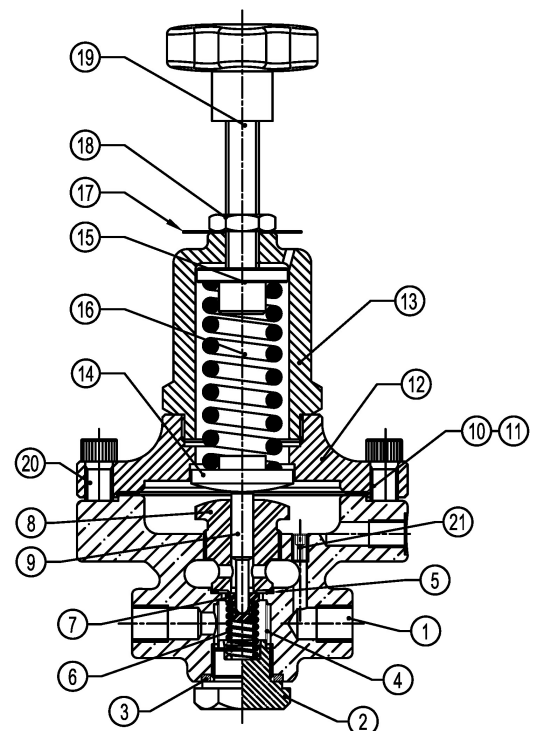

PRESSURE RANGES

SPRING COLOUR	GREEN w/ 1 diaphragm	BLUE w/ 1 diaphragm	RED w/ 2 diaphragms	BLACK w/ 2 diaphragms
Outlet spring range	0,07 to 0,5 bar * 0,35 to 2 bar	1,5 to 5,5 bar	3,5 to 8,5 bar	7 to 17 bar

* With special low pressure top assembled.

ORDERING CODES P7									
Valve model	P7SS	.	1	S		S		A	08
P7SS – Stainless steel pilot regulator	P7SS								
Outlet spring range									
Green spring 0,35 to 2 bar – single diaphragm			1						
Blue spring 1,5 to 5,5 bar – single diaphragm			2						
Red spring 3,5 to 8,5 bar – double diaphragm			3						
Black spring 7 to 17 bar – double diaphragm			4						
Dome loaded – 0,35 to 4 bar – single diaphragm a)			6						
Dome loaded – 2 to 17 bar – double diaphragm a)			7						
Application									
Steam				S					
Gases				G					
Seal material									
Metal to metal					(1)				
EPDM b)					E				
PTFE b)					T				
FPM / Viton b)					V				
Diaphragm									
Standard diaphragm						S			
Low pressure diaphragm						L			
Gauge port 1/4"									
Without gauge ports							(1)		
Gauge port on the left side (relative to the flow direction)							4		
Gauge port on the right side (relative to the flow direction)							3		
Gauge ports on both sides							2		
Pipe connection									
Threaded ISO 7 Rp								A	
Threaded NPT ANSI B1.20.1								C	
Size									
1/4"									08
3/8"									10
Special valves / Extras									
Full description or additional codes have to be added in case of non-standard combination.									E

(1) Omitted if a standard valve is requested.

a) The loading control pressure is approximately the same as the required downstream set-point pressure ($\pm 0,2$ bar).

b) Valve limited to the materials' maximum operating temperature. Contact manufacturer for more details.

Remarks: The external sensing connection must be requested with the order, when required.